



# TWINKO Solar Light Tower

## APPLICATIONS

Unlike other construction site light towers, TWINKO has removable double mast heads for storage. SOLTECH provides solar light fixtures for every application. At 16 feet high, TWINKO creates a wider illumination area that is ideal for parking lots, construction sites, mining camps, events, roadwork, and more.

## DESCRIPTION

TWINKO mobile solar light tower provides versatile temporary lighting. It's ideal for construction sites, natural disasters, and mining operations. The double heads can be assembled with SUNLIKE 20W/30W and SUNLIKE PRO 30W. TWINKO light tower can be easily transported from location to location.

CATALOG		COMMENTS
PROJECT		
PREPARED BY		
DATE		

## LIGHTING FIXTURE OPTIONS

- SUNLIKE PRO 30W X1 6,000 lumen
- SUNLIKE 30W X1 6,000 lumen
- SUNLIKE 20W X2 8,000 lumen  
(SOLAR FIXTURE NOT INCLUDED)



## ORDERING INFORMATION

TOWER	FIXTURE						
	SERIES	WATTAGE	OPTIC TYPE	COLOR TEMPERATURE	MOUNTING OPTIONS	FINISH	FIXTURE QTY
STLTWR01E=TWINKO Solar Mobile Tower	STLSTC=SUNLIKE	20=20W 4000 Lumens <i>(only for SUNLIKE)</i>	T2=TYPE II <i>(only for SUNLIKE 30W SUNLIKE PRO 30W)</i>	3=3000K 4=4000K 5=5000K 6=5700K	SF=Slip Fitter	GY=Gray	1=1
	STLSTCPRO=SUNLIKE PRO	30=30W 6000 Lumens	T3=TYPE III T4=TYPE IV <i>(only for SUNLIKE 30W SUNLIKE PRO 30W)</i>	2=2 <i>(only for SUNLIKE 20W)</i>			

-  -  -  -  -  -  -

## SPECIFICATION FEATURES



- Flexible Range of Visibility**
- 150 AH, 1,500 W integrated gel-battery ensures 120 cycles of raising and lowering the mast, one charge lasts an entire month.
  - 16 foot tower height provides a wider range of illumination area.



- Easy Deploy & Move**
- Forklift pocket, base 1m x 1m (40 in x 40 in, matches a standard pallet)
  - 4 manual stabilizer legs



- Heavy Duty Guarantee**
- Aluminium mast, 4 sections, 16 ft max.
  - Electrical winch rated to 3,000 lbs with limit sensor, DC 12V



- Lower Costs**
- No trenching, cabling, electricity nor diesel costs
  - Zero emission of greenhouse gases



- Clean, Quiet & Environmentally Friendly**
- No generator emissions
  - Quiet and produce no exhausts
  - Direct alternative to diesel, gas, or electric grid



- Meet Specific Lighting & Operating Requirements**
- 120VAC input plug
  - SUNLIKE mounting accessories included
  - Creates a wider illumination area at 16 ft high

**PRODUCT SIZE**

CATALOG		COMMENTS
PROJECT		
PREPARED BY		
DATE		

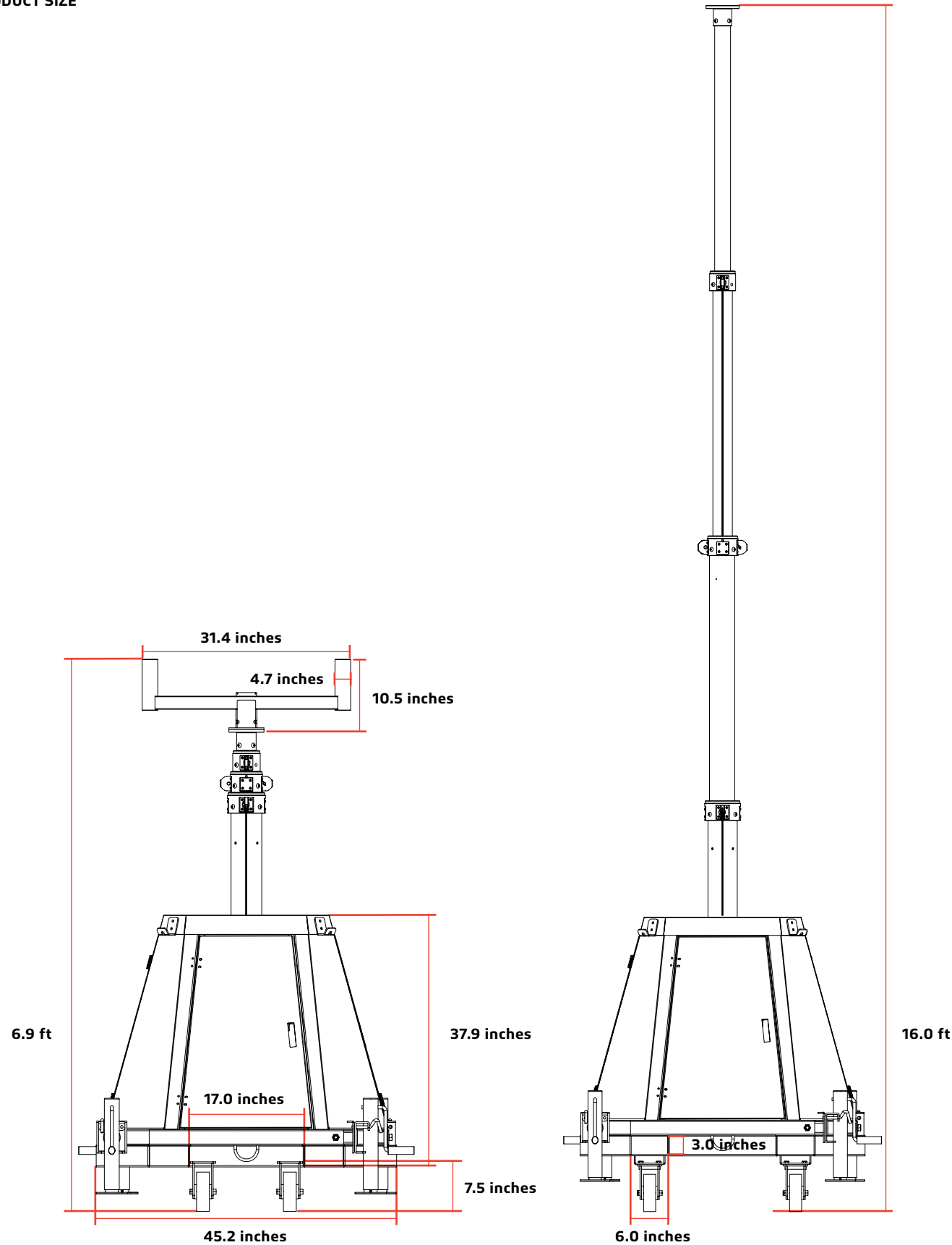

**SPECIFICATIONS**

CATALOG		COMMENTS
PROJECT		
PREPARED BY		
DATE		

Specifications	TWINKO
Max Height	16 ft (Without Luminaire)
Collapsed Height	6.9 ft (Without Luminaire)
Mast Material	Steel
Mast Profile	Round
Mast Sections	4
Operation	Electric Winch 3000 Lbs, DC12V
Battery	GEL DC12V 150AH, 1,200 times Lift and Down Autonomy
Charger	1,500W AC 110V Input
Mast Max Load	88 Lbs
Max Wind Speed	90 mph
Warning Strips	Included
Lift Limit Stopper	Included
Lifting Eyes	X4
Fork Pockets	Included
Wheel	Included (With Brake)
Mast Flange	Included
Weight	1,210 Lbs (Without Luminaire)
Dimensions	45.2 inches X 45.2 inches X 83.0 inches (Collapsed Without Luminaire)

01. Install Tenon

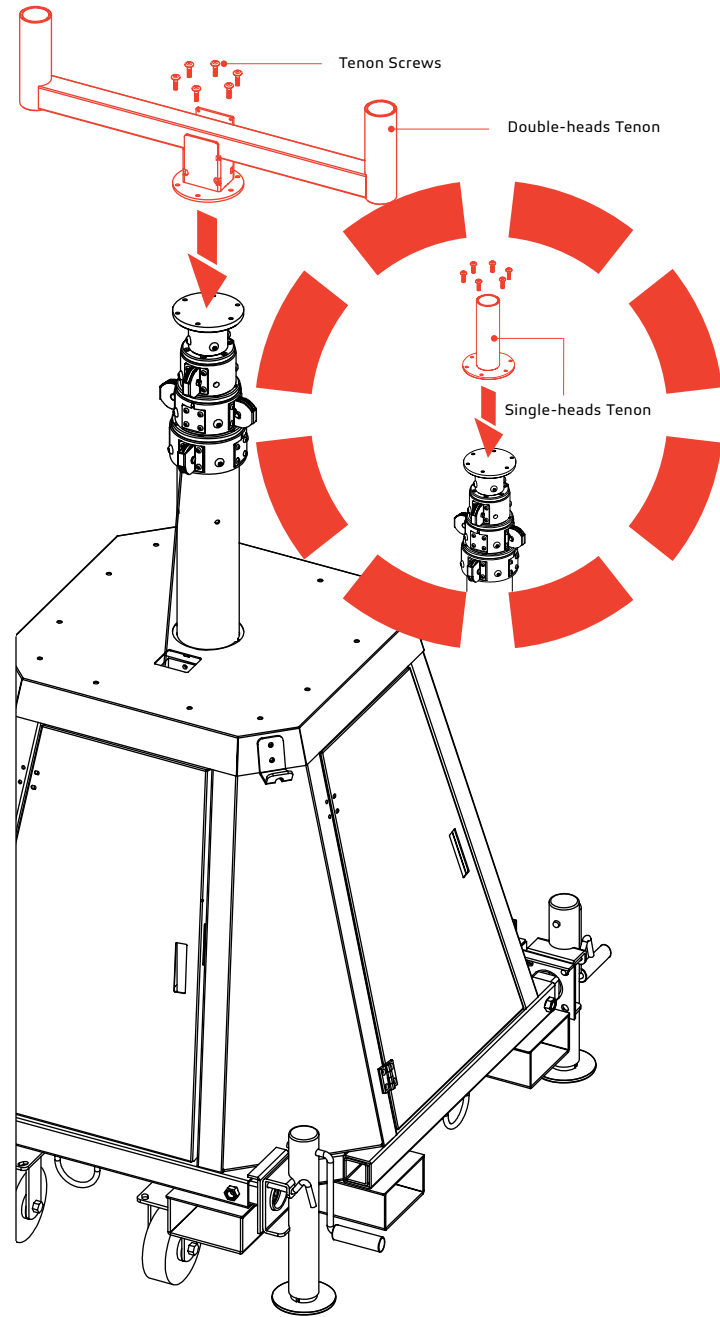

Install Tenon on the top of the pole.

CATALOG	PROJECT	COMMENTS

02. Install Luminaire

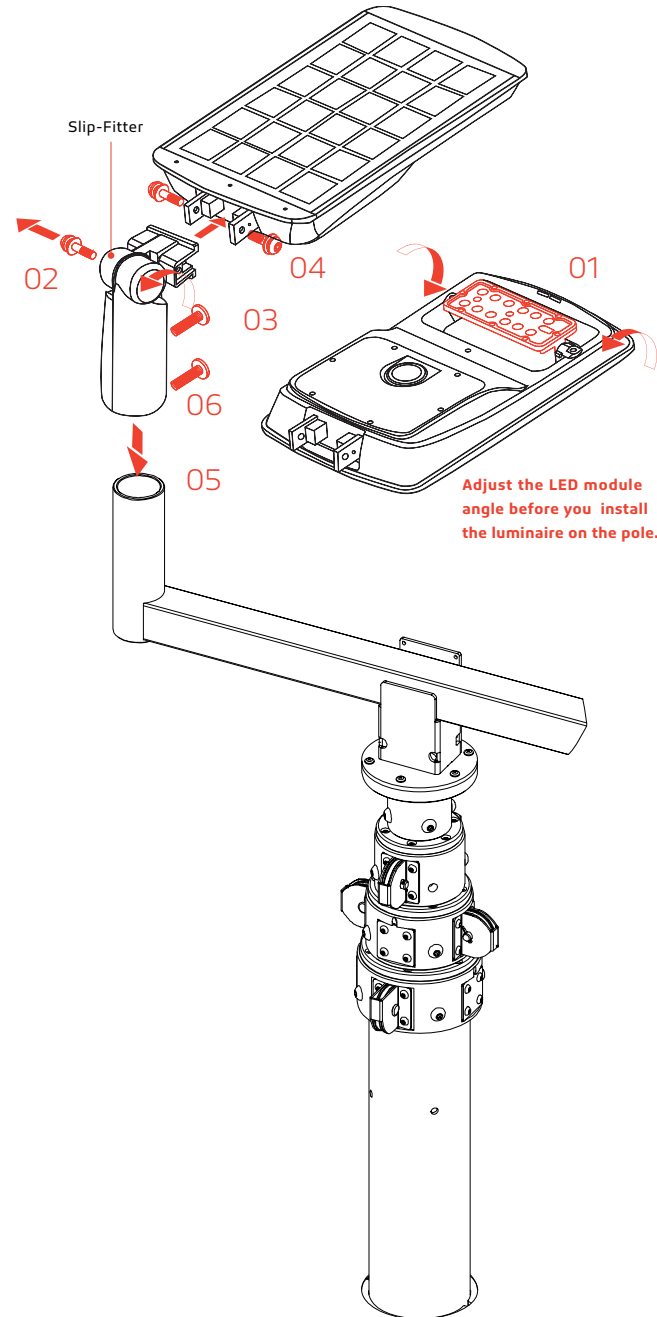

03. Adjust The Pole Height

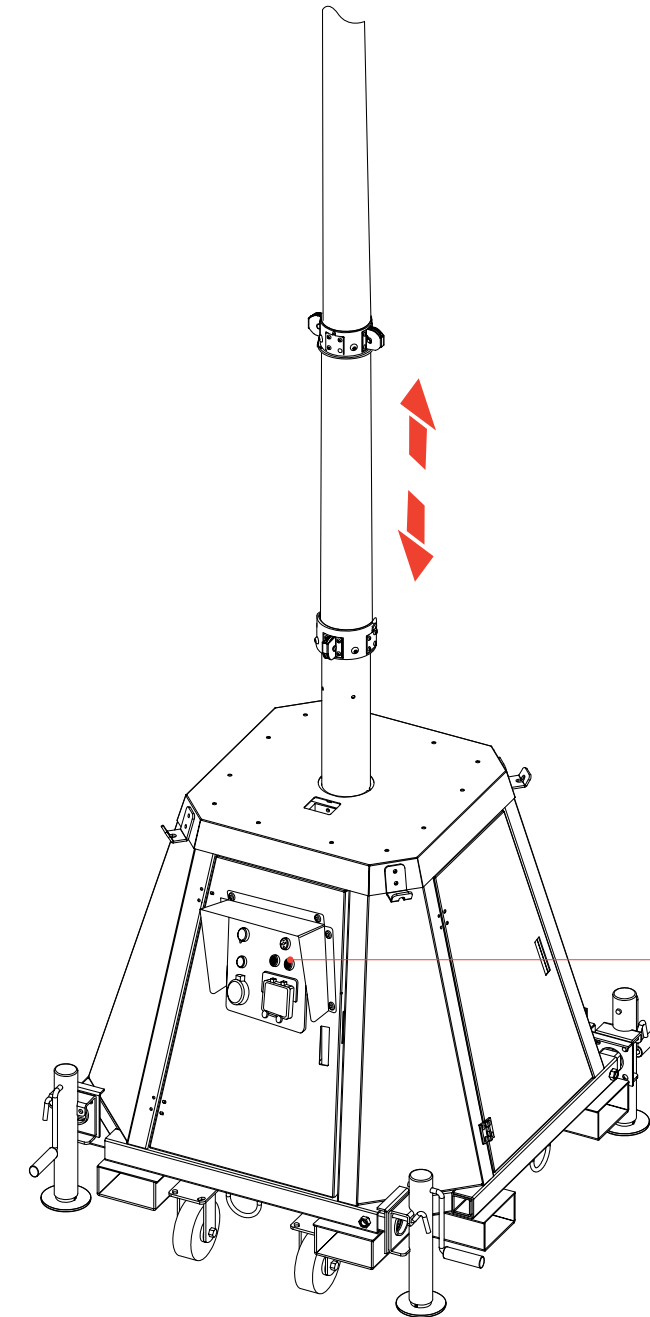

Press the UP and DOWN buttons on the control board to adjust the pole height.

CATALOG	PROJECT	COMMENTS

03. Adjust The Pole Height

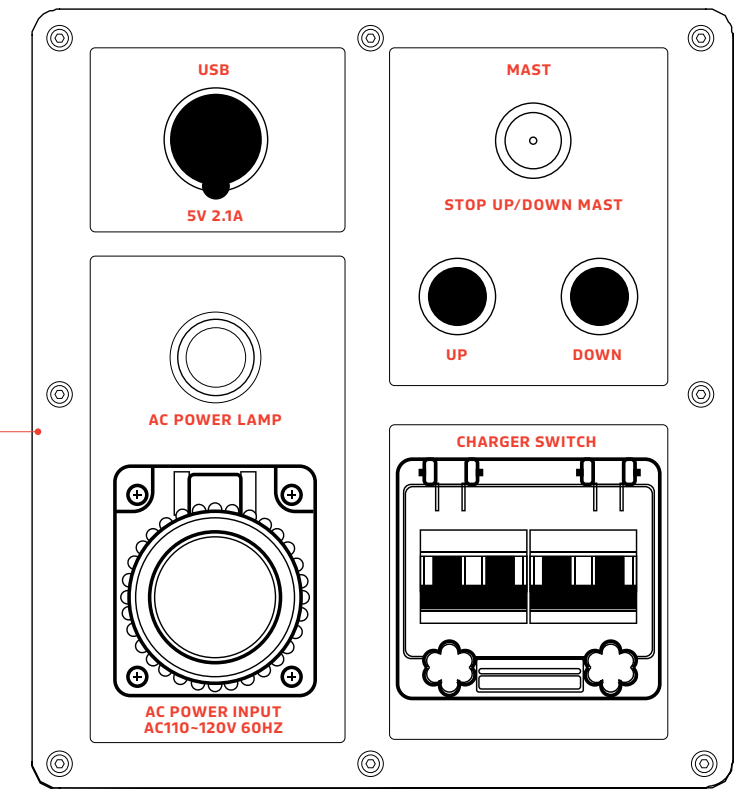

Control Board



## TWINKO Solar Light Tower

CATALOG	PROJECT	COMMENTS

**TWINKO with SUNLIKE 20W**  
(Four light towers on a regular soccer field)

**Lights:** Two 20W fixtures per tower  
**Light height:** 16ft  
**Lighting Area:** 400 X 250 ft  
**Luminosity:** 0.23 fc average across entire area

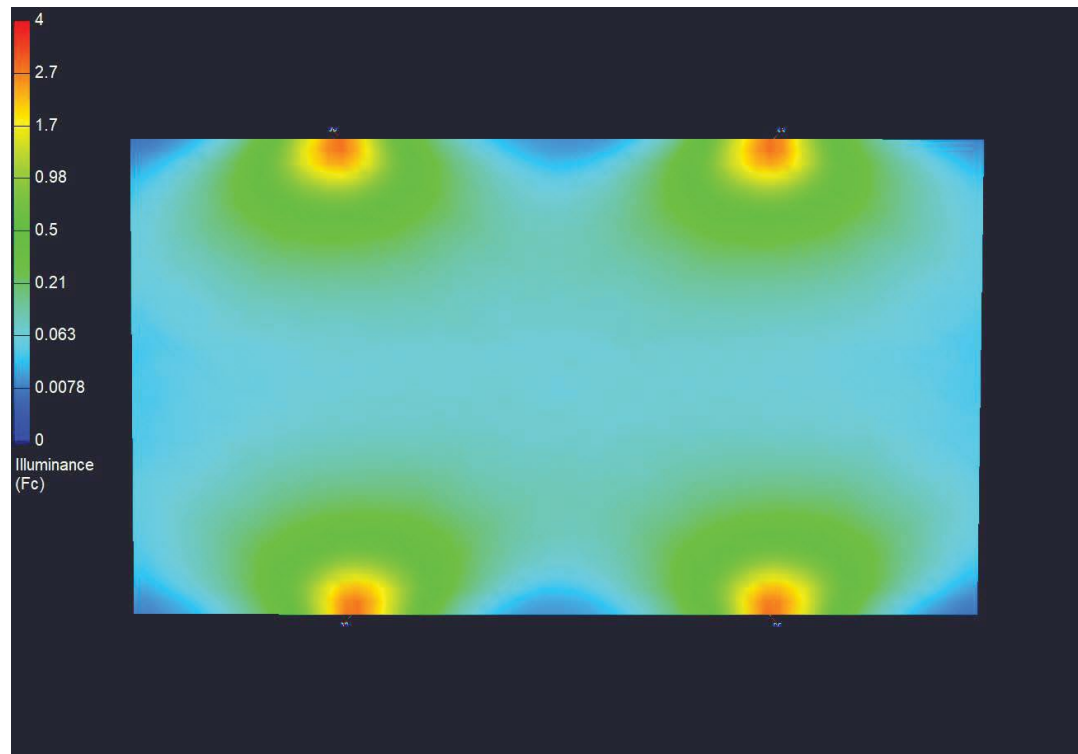
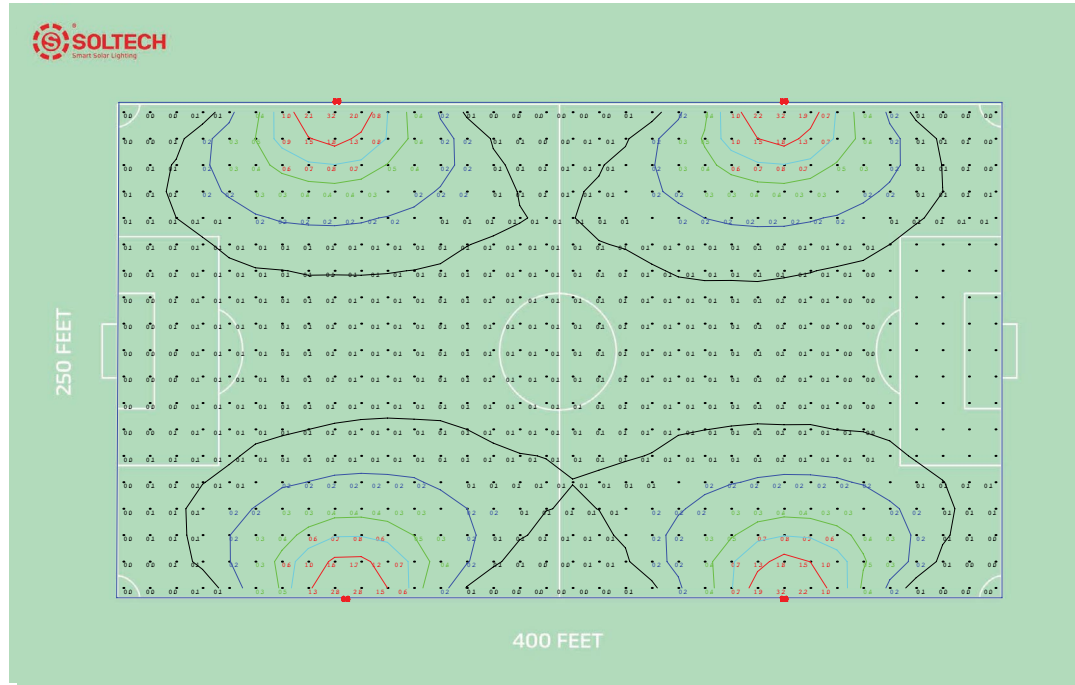

## TWINKO Solar Light Tower

CATALOG	PROJECT	COMMENTS

**TWINKO with SUNLIKE 30W**  
(Eight light towers on a regular soccer field)

**Lights:** One 30W fixtures per tower  
**Light height:** 16ft  
**Lighting Area:** 400 X 250 ft  
**Luminosity:** 0.33 fc average across entire area

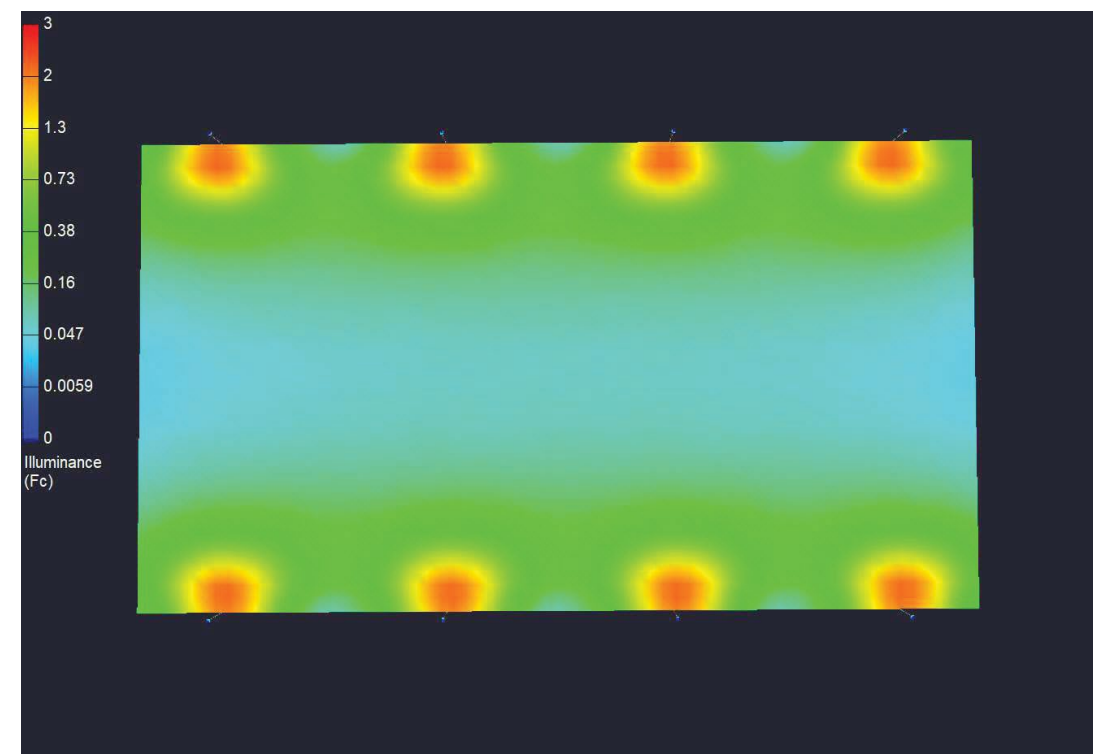
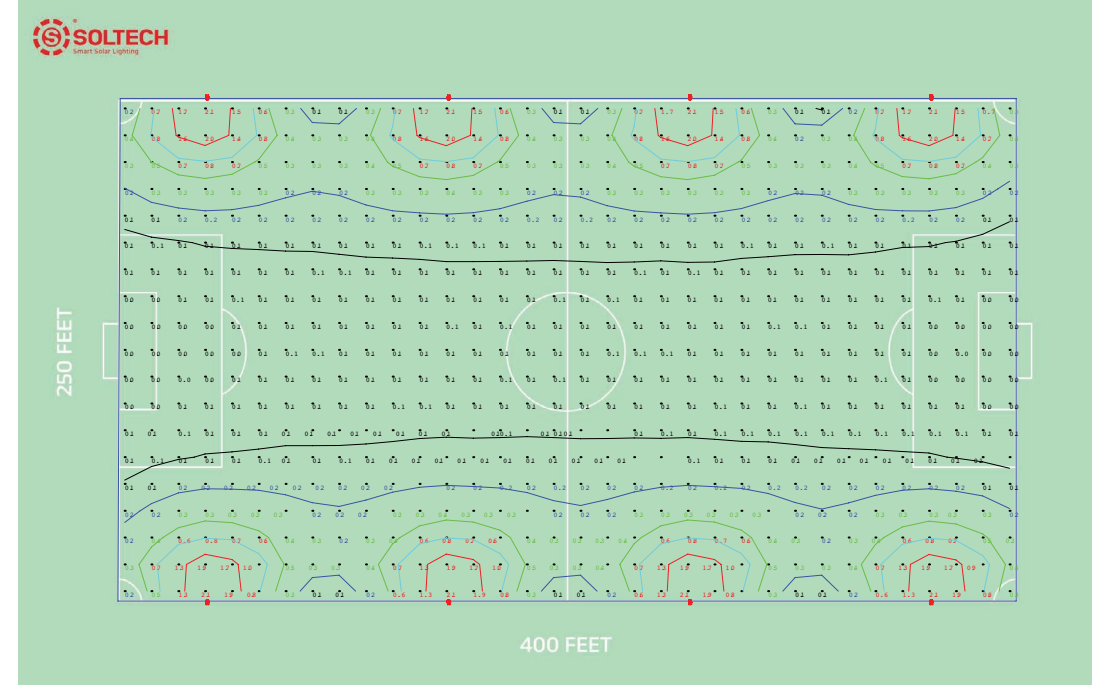



# TWINKO Solar Light Tower

CATALOG		COMMENTS
PROJECT		
PREPARED BY		
DATE		

### WARRANTY

**TWINKO Solar Mobile Tower products are covered by a 5 year limited warranty. SOLTECH warrants to the original purchaser that this product is free from defects in materials and workmanship for the period of 5 years from date of purchase. To obtain warranty service please contact your local distributor or sales rep for further instruction.**



1460 Park Avenue.  
Emeryville, CA 94608 USA

[www.soltechlighting.com](http://www.soltechlighting.com)

*SOLTECH LLC reserves the right to update all product data sheets at any time. Consult SOLTECH marketing specialists for publication updates at [hello@soltechlighting.com](mailto:hello@soltechlighting.com)*

*Copyright©2022-2023 SOLTECH LLC,  
All Rights Reserved.*