

Alphalite

INFINITY LED LINEAR STRIP

PROJECT NAME

CATALOG NO.

TYPE

DATE

NOTE

IRT Series

Infinity Retrofit Kit Series

DESCRIPTION

The Infinity LED Troffer Retrofit Kit series combines the benefits of long life, controllability, and energy savings with elegant design and superior quality of light. The IRT retrofit solution optimizes LED optics and electronics to deliver energy savings and high performance while being extremely quick and easy to install.

Installation video: <https://www.youtube.com/watch?v=NUFvr3YMhbg>

APPLICATION

Indoor general/ambient illumination. Idea for offices, retail, and other architectural spaces that demand energy demand reduction and high quality light.

SPECIFICATION FEATURES

Construction

Rugged construction: solid die-formed, cold-rolled steel. Interior utilizes highly reflective powder coat finish. All surfaces coated and baked post-fabrication with high gloss powder-paint. Diffuser lens provides even and consistent light while eliminating pixelation. Tool-less removal of diffuser allows access to LED array. LED module and driver are replaceable. Easy and convenient installation utilizes existing luminaire body, reduces labor hours. Housing and optics maintain damp location rating with all internal components.

Electrical

Luminaire utilizes long life, high efficacy LEDs and a highly efficient, reliable LED driver. 120V-277V input voltage for increased versatility. 0-10V continuous dimming comes standard. Ideal when used in conjunction with controls and sensors. Comes equipped with quick disconnect for compliance with US code

Finish

Highly reflective powder coat finish. Baked white matte paint, applied after fabrication.

Optics

Occupants can realize a productive and comfortable atmosphere through enhanced light quality and distribution. Diffuser shape, pattern, and opacity designed in conjunction with precisely-engineered reflector cavity angles to distribute LED light consistently, reducing glare and pixelation.

Mounting

Installs within existing troffer and louvers. Utilizes existing luminaire body, eliminating the need to remove and dispose of old hardware. LED module arrays and drivers accessible from fixture during service and operation, no need to access via plenum.

Certifications / Regulatory

UL/cUL listed. All components used have UL approval. UL Class 2. Power supply: SCP, OTP, OVP protection, FCC Part 15 Class B, UL8750 Class 2. DLC QPL..

Warranty

7-year limited warranty. See complete warranty terms for details.



Quick Ship Product

IRT-24VL(23S)/835
IRT-24VL(23S)/840
IRT-24L(36S)/840
IRT-22L(23S)/840
IRT-22H(33S)/840

ORDERING INFORMATION

Sample Number: IRT-24L(36S)/840

IRT	22	H(40)	8	40	(Blank)	(Blank)
Series	Form Factor	Lumen Package	CRI	CCT	Input Voltage	Dimming
IRT - Infinity LED Troffer Retrofit Kit	22 - 2'x2' 24 - 2'x4' 14 - 1'x4'	VL- Very Low Wattage L - Low Wattage H - High Lumen *see energy performance data for details	8 - 83+ CRI	35 - 3500K 40 - 4000K 50 - 5000K	(Blank) - 120V-277V 347 - 347V	(Blank) - 0-10V

Options

Controls

DMMS - Integrated step dimming
microwave motion sensor

DL - Integrated daylight harvesting

SMC - Wireless Smart Control System

Emergency Backup

EM700 - 700lm
EM1400 - 1400lm
EM2000 - 2000lm



Specifications and dimensions subject to change without notice.

10715 Springdale Ave, Ste 4, Santa Fe Springs, CA 90670

Tel: 888.287.9228

Fax: 888.258.9183

www.alphalite.com

SUMMARY

Input Voltage	120V-277V
Input Power	See energy data for details
Power Factor	> 0.95
THD (Max.)	10%
Efficacy	> 125 LPW
Delivered Lumens	See energy data for details
Controls/ Dimming	Full Range 0-10V dimming standard
Dimming Range	10-100%
CRI	> 83
CCT	3500K, 4000K, 5000K
Operating Temp.	-20 ~ +55 C
Rated Life	70,000 hours

ENERGY PERFORMANCE DATA

Form Factor	Part No.	Rated Wattage (W)	Tested Wattage (W)	Delivered Lumens (lm)	Efficacy (lm/W)
2' x 2'	IRT-22L(23S)/835	23	22.5	2876	128
	IRT-22L(23S)/840			3000	130
	IRT-22L(23S)/850			3000	130
	IRT-22H(33S)/835	33	32.5	4003	124
	IRT-22H(33S)/840			4158	126
2' x 4'	IRT-24VL(23S)/835	23	23	2976	130
	IRT-24VL(23S)/840			3036	132
	IRT-24VL(23S)/850			3059	133
	IRT-24L(36S)/835	36	37	4907	131
	IRT-24L(36S)/840			4752	132
	IRT-24L(36S)/850			4790	133
	IRT-24H(44)/835	44	41	5125	125
	IRT-24H(44)/840			5330	130
IRT-24H(44)/850	5371			131	
1' x 4'	IRT-14L(23S)/835	23	23	2875	125
	IRT-14L(23S)/840			2898	126
	IRT-14L(23S)/850			2921	127
	IRT-14H(33S)/835	33	33	4125	125
	IRT-14H(33S)/840			4158	126
	IRT-14H(33S)/850			4191	127

PHYSICAL PARAMETERS

DIMENSION

IRT-22

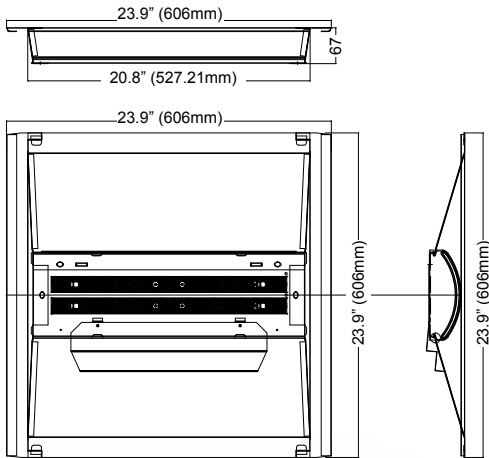

IRT-24

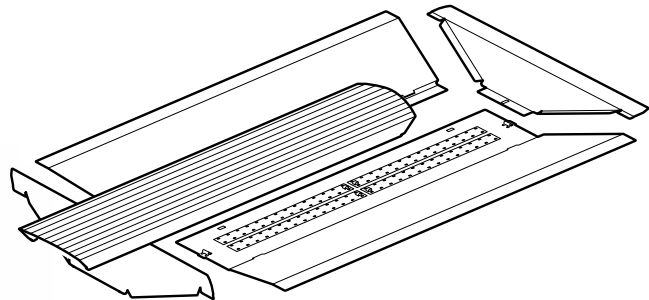
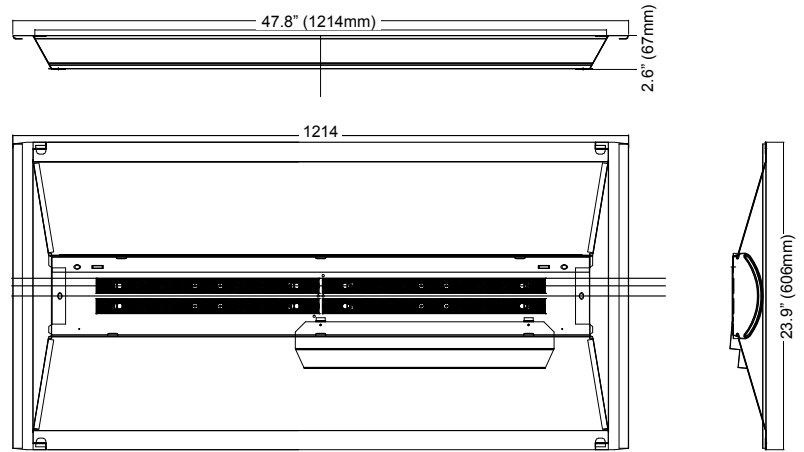

-DMMS control pre-commissioning

Sample Number: -DMMS (10-5M-L3-S10M)

10	3M	L3	S10M	(Blank)
Detection Area	Hold Time	Low Mode	Stand-by Period	Daylight Sensor
10 - 100%	30M - 30 min.	L5 - 50%	SN - ∞	(Blank) - Disable
7 - 75%	20M - 20 min.	L3 - 30%	S1H - 1 hr.	D50 - 50 lux
5 - 50%	10M - 10 min.	L2 - 20%	S30M - 30 min.	D10 - 10 lux
1 - 10%	5M - 5 min.	L1 - 10%	S10M - 10 min.	D2 - 2 lux
	1M - 1 min.		S5M - 5 min.	
	30S - 30 sec.		S10S - 10 sec.	
	5S - 5 sec.		(Blank) - Disable	

Detection Area: Detection area can be reduced to fit precisely each application.

Hold Time: The time period the luminaire remains at 100% illumination after no motion detected.

Low Mode: The selected low light level after the hold time.

Stand-by Period: The time period the luminaire remains at "Low Mode" before it completely switched off in the long absence of people. When set to "∞" mode, the low light level is maintained until motion is detected.

Daylight Sensor: The sensor can be set to only allow the luminaire to illuminate below a defined ambient brightness threshold. When set to "Disable" mode, the daylight sensor will switch on the luminaire when motion is detected regardless of ambient light level.

****Noted that daylight sensor is active only when the luminaire switches off****

WIRELESS SMART CONTROL SYSTEM (ASMC)

The Alphilite Wireless Smart Control System is an ideal choice to provide convenient control of lighting. The LED controller uses wireless technology to communicate with other self-powered products in the system and provides an amazingly simple solution for dimming control of LED lighting

APPLICATION

Versatile solution for general purpose applications. Ideal for multi level building, offices, school, warehouse, manufacturing facilities, and spaces that demand energy demand reduction and high quality light.

BENEFITS

- Reliable, longer indoor range wireless communication
- Easy Design-in
- License-free
- Self-powered
- Lower energy costs
- Lower installation costs
- Strength of interoperability
- Convenient access to replaceable, standard components reduces life cycle costs

