

6" LED ARCHITECTURAL RETROFIT

Project:	
Type:	
Catalog #:	

STANDARD

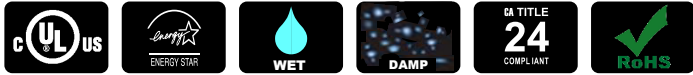

The 6" Architectural LED series are commercial-grade quality luminaires. These retrofit kits convert nearly any existing 6-inch incandescent, HID or CFL into LED fixtures. They are upgradeable to the latest and most advanced LED technology. Enjoy energy savings and maintenance-free service with 50,000 hours of life in typical commercial applications.

FEATURES

- Installs from below ceiling, retrofit housing is secured in place by 3 tension clips.
- 28 Watt available in 3000K.
- 40 Watt available in 4000K.
- Conduit quick-connects
- Consistent fixture-to-fixture color temperature within 3 MacAdam Ellipses.
- Integral heat sink conducts heat away from LED Light engine.
- Driver is accessible from below the ceiling and can be upgraded to accommodate future technology improvements.
- Universal 120-277 AC voltage (50/60Hz)
- 0-10v dimming
- Color rendering index ≥ 80 .
- Long life LEDs - up to 50,000hours.
- Operation Temp. $-30^{\circ}\text{C}\sim 40^{\circ}\text{C}$ ($-22^{\circ}\text{F}\sim 104^{\circ}\text{F}$).



WARRANTY & LISTINGS

- cULus Listed.
- Energy Star listed.
- Suitable for wet locations (not suitable for coastal/salt water area).
- Suitable for damp locations.
- RoHS compliant.
- 5-year warranty of all electronics and housing.

DIMENSIONS

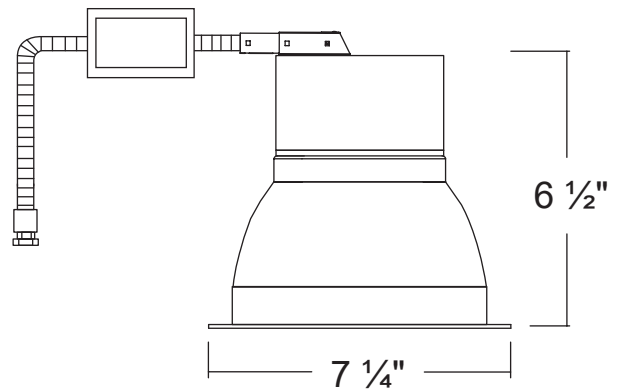

ORDERING INFORMATION

Model	Color Temperature	Luminaire Lumens	Luminaire Watts	Lumens / Watt
BRK-LED28ARC6-3K	3000k	2210	28	79
BRK-LED40ARC6-4K	4000k	2980	40	75